



**INTERNATIONAL TRACTORS LIMITED,
SONALIKA INTERNATIONAL WORLDTRAC - 60 RX TRACTOR**



सत्यमेव जयते

भारत सरकार

कृषि एवं किसान कल्याण मंत्रालय
(कृषि, सहकारिता एवं किसान कल्याण विभाग)

GOVERNMENT OF INDIA

MINISTRY OF AGRICULTURE AND FARMERS WELFARE

(DEPARTMENT OF AGRICULTURE, CO-OPERATION AND FARMERS WELFARE)

केन्द्रीय कृषि मशीनरी प्रशिक्षण एवं परीक्षण संस्थान
ट्रैक्टर नगर, बुदनी (म.प्र.) ४६६ ४४५

CENTRAL FARM MACHINERY TRAINING & TESTING INSTITUTE

(An ISO : 9001 - 2008 Certified Institute)

Tractor Nagar, Budni (M.P.) 466 445

E-mail fmti-mp@nic.in

Website : <http://cfmtti.dacnet.nic.in>

Telephone : 07564 - 234729

Fax : 07564 - 234743



Subsequent to the examination of the case in the light of Indian Standard IS:12207-2014 the following tests were considered to be carried out:

- Specification checking
- Nominal speed test
- Two hour maximum PTO power performance test
- Drawbar performance test (unballast condition)

2. FUEL AND LUBRICANTS

2.1 Fuel

: The High-speed diesel oil supplied by M/s Indian Oil Corporation Limited having density of 0.836 g/cc at 15°C was used.

2.2 Lubricants:

S. No.	Particulars	As recommended by the manufacturer	As used during the test
1.	Engine & air cleaner oil	SAE 20W40	As recommended
2.	Transmission, differential, final drive, brake and hydraulic system oil	Tract elf 2412	Oil originally filled in the tractor was not changed
3.	Steering system	SAE-EP -80	-do-
4.	Grease	MP Grease	MP Grease

3. ESSENTIAL TESTS

3.1 SPECIFICATIONS

3.1.1 Tractor:

	<u>Base model</u>	<u>Variant model</u>
Make	: International Tractors Limited	International Tractors Limited
Model	: Sonalika International Worldtrac 60 RX 4WD	Sonalika International Worldtrac 60 RX
Type	: Four wheel driven, Agricultural Tractor	Four wheeled, rear wheel drive, agricultural tractor.
Year of manufacture	: 2013	2015
Chassis serial number	: BYDDV324406MS	FYDDU495317MS
Country of origin	: India	India

3.1.2 Engine:

Make	: International Tractors Ltd.	International Tractors Ltd.
Model	: 4100 FL	4100 FL
Type	: Four stroke, naturally aspirated, water cooled, direct injection diesel engine.	
Serial number	: 4100FL23L323818F9	4100FL53E489018
Country of origin	: India	India
Engine speed (rpm), (Manufacturer's recommended production setting):		
- Maximum speed at no load	: 2350 to 2450	2350 to 2450
- Low idle speed	: 600 to 700	600 to 700
- Speed at maximum torque	: 1100 to 1300	1100 to 1300



T-1044/1569/2016

**INTERNATIONAL TRACTORS LIMITED,
SONALIKA INTERNATIONAL WORLDTRAC -60 RX TRACTOR
Commercial (Variant)**

7. SUMMARY OF OBSERVATIONS, COMMENTS & RECOMMENDATIONS

7.1 On the basis of test conducted the performance results have been summarized as evaluative (mandatory) and non – evaluative (not mandatory) parameters applicable for qualifying Minimum Performance Criteria as per clause-4 table-1 of Indian Standard 12207: 2014 for acceptance of tractor for the purpose of subsidies/NABARD financing for the applicable features for this tractor model.

Sl. No.	Characteristic	Category (Evaluative / Non Evaluative)	Requirements as per IS: 12207-2014	Values declared by the applicant/ requirement		As observed		Whether Variant model meets the requirements (Yes/No)
				Base model	Variant Model	Base model	Variant model	
1	2	3	4	5 a	5 b	6 a	6 b	7
7.1.1 PTO Performance :								
a)	- Max. power under 2 h test, (kW) (Natural ambient condition)	Evaluative	Declared value to be achieved with a tolerance of: -5 / +10% for PTO power >26 kW. -7.5/+10% for PTO power ≤ 26 kW or -5 / +10% for engine power >26 kW. -7.5/+10% for engine power ≤ 26 kW	36.3	36.3	37.4	36.8	Yes
b)	Power at rated engine speed, (kW)	Non Evaluative	-do-	36.3	36.3	36.9	36.8	Yes
c)	Specific fuel consumption corresponding to maximum power, (g/kWh)	Non Evaluative	+ 5%	265	265	262	273	Yes
7.1.2 Drawbar performance :								
a)	Maximum drawbar pull with standard ballast corresponding to 15 percent wheel slip, (kN)	Non Evaluative	Minimum 65% of static mass with ballast	18.96 (D) 18.80 (R)	16.63 (D) 16.22 (R)	24.36	21.98	Yes
b)	Maximum drawbar power with standard ballast, (kW).	Evaluative	Minimum 80 % of PTO power as referred in Sl No. i a) of PTO performance in case of tractors having total static mass > 1500 kg.	29.9 (R) Mini mum	29.4 (R) Mini mum	30.9	32.0	Yes



1	2	3	4	5 a	5 b	6 a	6 b	7
7.1.3	Labelling of tractors (Provision of labelling plate):							
1)	Make	Evaluative	Should conform to the requirements of CMVR along with declared value of PTO HP	International Tractors Ltd.	International Tractors Ltd.			Yes
2)	Model	Evaluative		Sonalika International Worldtrac 60RX 4WD	Sonalika International Worldtrac 60RX			Yes
3)	Year of manufacture	Evaluative		2013	2015			Yes
4)	Engine serial number	Evaluative		4100FL23L3 23818F9	4100FL53E 489018			Yes
5)	Chassis number	Evaluative		BYDDV3244 06MS	FYDDU9531 7MS			Yes
7.1.4	Literature (Submission to test agency)							
(a)	Operator manual	Evaluative	Provided/ Not Provided	Provided	Provided			Yes
(b)	Parts Catalogue	Evaluative	Provided/ Not Provided	Provided	Provided			Yes
(c)	Workshop/ Service manual	Evaluative	Provided/ Not Provided	Provided	Provided			Yes
7.1.5	CATEGORY OF BREAKDOWNS / DEFECTS :							
S. No.	Category of breakdowns	Category (Evaluative / Non Evaluative)	Requirements as per IS: 12207-2014	As observed	Whether meets the requirements (Yes/No.)			
1.	Critical	Evaluative	No critical breakdown	None	Yes			
2.	Major	Evaluative	Not more than two and neither of them should be repetitive in nature	None	Yes			
3.	Minor	Evaluative	Not more than five and frequency of each should not be more than two.	Mn - 8 & Mn- 13	Yes			
4.	Total breakdowns	Evaluative	In no case, the total number of breakdowns should exceed five, that is, (2 major + 3 minor) or 5 minor breakdowns.	Two (2- Minor)	Yes			

7.2 Salient Observations:**7.2.1 Laboratory tests:****7.2.1.1 PTO Performance:**

- i) The maximum PTO power in case of base and variant models was observed as **37.4 & 36.8 kW** against the declaration of **36.3 kW** respectively, which is within the specified limit.
- ii) The specific fuel consumption in case of base and variant models corresponding to maximum power was observed as **262 & 273g/kWh** against the declaration of **265 g/kWh** respectively, which is within the tolerance limit.

7.2.1.2 Three point linkage:

The lateral distance from lower hitch point to the centre of tractor does not meet the requirement of IS: 4468 (Part-1)-1997. This should be looked into for necessary corrective action.



1044/1569/2016

**INTERNATIONAL TRACTORS LIMITED,
SONALIKA INTERNATIONAL WORLDTRAC -60 RX TRACTOR
Commercial (Variant)**

- 7.2.1.3 Linkage drawbar:**
Some of the parameters of linkage drawbar conform to Cat.I and some of them conform to Cat.II. In view of the spirit of standardization, necessary improvements may be incorporated.
- 7.2.1.4 Operator's Seat:**
Longitudinal distance from seat index point to the center of steering control wheel.
- 7.2.1.5 Location and operation of operator's control:**
The working clearance around the position lever to draft control and mudguard was observed as 35 mm against the minimum requirement of 70 mm as per per IS: 12239 (Part 2)-1996 This should be looked into for necessary corrective action.
- 7.3 Maintenance / Service Problems:**
- i) After completion of PTO performance test presence of oil in clutch housing was observed due to leakage from engine main oil seal. There after engine main oil seal replace with new one (Part no.703402030A). This breakdown /defect has been categorized as minor (Mn-8).
 - ii) Again the oil is coming from clutch housing inspect the oil leakage from transmission bearing housing cover (Part no.10006171AA) was tightened the cover bolt & sealant on transmission housing cove cap. This breakdown /defect has been categorized as minor (Mn-13).
- 7.4 Recommendation with regard to safety on tractor:**
The following requirements, inter alia, may be considered for incorporation on the tractor:
- i) Provision of safety against accidental start of the engine.
 - ii) Provision for spark arresting device in exhaust system.
 - iii) Provision for retaining the fuel shut-off lever in "STOP" position.
 - iv) The working clearance between the draft & position control lever may be provided as per IS: 12239 (Part-2) – 1999.
 - v) Provision of PTO shaft master shield.
 - vi) Cautionary notice as per para 11.2 of IS:12239 (Part-2)-1999
- 7.5 Adequacy of Literature supplied with machine:**
- 7.5.1** Literature was supplied with the tractor for reference during the test. It is therefore, recommended that following literature may be brought out as per IS: 8132-1999 (Reaffirmed in March, 2009) for the guidance of users and service personnel in national as well as regional languages for this model of tractor.
- a) Operator's Manual
 - b) Parts catalogue
 - c) Service Manual
- 7.5.2** Information related to PTO, Drawbar and hydraulic performance of the tractor such as, maximum PTO power, rated PTO power, power at standard PTO speed, maximum torque, backup torque, specific fuel consumption, maximum drawbar power & pull, hydraulic pump discharge rate, hydraulic power & lifting capacities etc should be included in the technical specification of the tractor for the guidance of the user's.

The results of the tests carried out on variant model "International Tractor Ltd., Sonalika International Worldtrac 60 RX" have been compared with those on base model "International Tractor Ltd., Sonalika International Worldtrac 60 RX 4WD" and found within the limit, as specified in Indian Standard:12207-2014.

TOR

T-1044/1569/2016

**INTERNATIONAL TRACTORS LIMITED,
SONALIKA INTERNATIONAL WORLDTRAC -60 RX TRACTOR
Commercial (Variant)**



8. CITIZEN CHARTER

Time frame for Testing & Evaluation as per Citizen Charter	Duration of Test	Whether the Test Report is released within the time frame given in Citizen Charter	Remarks
10 Months	8 Month (March to October,2016)	Yes	None

TESTING AUTHORITY:

C.S.RAGHUWANSHI
 AGRICULTURAL ENGINEER

C.V.CHIMOTE
 TEST ENGINEER

Y.K. RAO
 SENIOR AGRICULTURAL
 ENGINEER

J.J.R.NARWARE
 DIRECTOR

9. Applicant's Comment

Para No.	Our Reference	Applicant's Comment
9.1	3.1.20.3,3.1.20.4, 3.1.20.5 ,7.2.1.2 & 7.3	We will look into this & make sure in production.
9.2	7.4	We will look into for corrective actions.

34



TT-1044/1569/2016

INTERNATIONAL TRACTORS LIMITED,
SONALIKA INTERNATIONAL WORLDTRAC -60 RX TRACTOR
Commercial (Variant)

ANNEXURE-I

TRACTOR RUN HOURS DURING TEST

A.	LABORATORY AND TRACK TESTS:	HOURS
1.	Running-in	
2.	PTO performance test	3.7
3.	Theoretical speed test	2.7
4.	Drawbar performance test (with standard ballast)	7.8
B.	Miscellaneous test and other run hours including idle run, transportation, trials and preparation for test	0.8
	TOTAL:	15.0



ANNEXURE-II

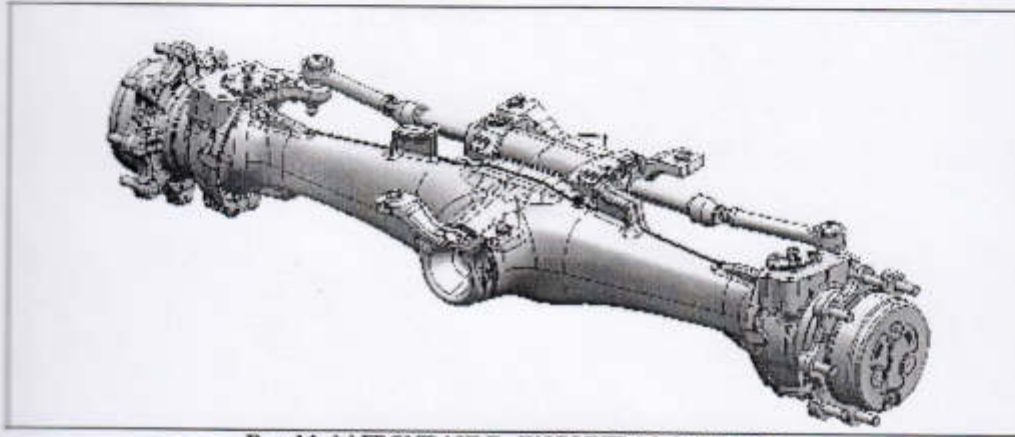

Base Model FRONT AXLE - WORLDTRAC 60 RX 4WD

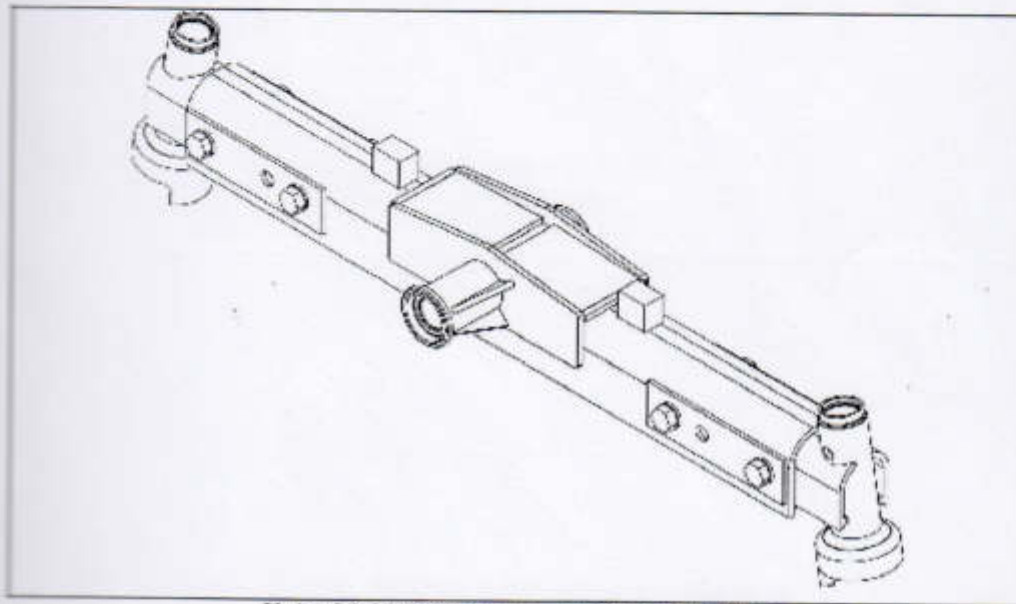

Variant Model FRONT AXLE - WORLDTRAC 60 RX