

व्यावसायिक परीक्षण रिपोर्ट—वैरिएंट (प्रथम बैच)
COMMERCIAL TEST REPORT-Variant (1st Batch)

संख्या / No. : T-1509/2036/202
माह / Month : January, 202

(यह परीक्षण रिपोर्ट 31/01/2026 तक वैध है। / THIS TEST REPORT IS VALID UP TO : 31/01/2026)



**INTERNATIONAL TRACTORS LIMITED,
SONALIKA INTERNATIONAL WORLDTRAC 60 RX TRACTOR**



सत्यमेव जयते

भारत सरकार

कृषि एवं किसान कल्याण मंत्रालय
कृषि, सहकारिता एवं किसान कल्याण विभाग
मशीनीकरण एवं प्रौद्योगिकी प्रभाग

GOVERNMENT OF INDIA

MINISTRY OF AGRICULTURE AND FARMERS WELFARE

(Department of Agriculture, Cooperation & Farmers Welfare, Mechanization & Technology Division)

केन्द्रीय कृषि मशीनरी प्रशिक्षण एवं परीक्षण संस्थान
ट्रैक्टर नगर, बुदनी (म.प्र.) ४६६ ४४५

CENTRAL FARM MACHINERY TRAINING & TESTING INSTITUTE
(An ISO : 9001 - 2015 Certified Institute)

Tractor Nagar, Budni (M.P.) 466 445

E-mail fmti-mp@nic.in

Website : <http://www.fmttibudni.gov.in>

Telephone : 07564 - 234729, 234743

Page 1 of 33

T- 1509/2036/2021	INTERNATIONAL TRACTORS LIMITED, SONALIKA INTERNATIONAL WORLDTRAC 60 RX TRACTOR- COMMERCIAL- VARIANT (1st BATCH TEST)
	THIS TEST REPORT IS VALID UPTO: 31/01/2026

2. FUEL AND LUBRICANTS

2.1 Fuel : The High-speed diesel oil supplied by M/s Indian Oil Corporation Limited having density of 0.836 g/cc at 15°C was used.

2.2 Lubricants:

S. No.	Particulars	As recommended by the manufacturer	As used during the test
1	2	3	4
1.	Engine oil	SAE 20W40	As recommended
2.	Steering housing oil	SAE-EP -80	As recommended
3.	Gearbox, differential, rear axle, rear final drive, brake & hydraulic system oil	Tract elf 2412	Oil originally filled in the tractor system were not changed
4.	Grease	MP Grease	MP Grease

3. ESSENTIAL TESTS

3.1 SPECIFICATIONS

3.1.1 Tractor:

Make : International Tractors Limited
 Model : Sonalika International Worldtrac 60 RX
 Brand name : None
 Type : Four wheeled, Rear-wheel driven, unit construction, General Purpose, Agricultural Tractor.
 Year of manufacture : 05/20
 Chassis number : FXDDH927703MS
 Country of origin : India

3.1.2 Engine:

Make : International Tractors Ltd.
 Model : 4100 FL
 Type : Four stroke, naturally aspirated, liquid cooled, direct injection diesel engine.
 Serial number : 4100FL04C919936F9
 Country of origin : India

3.1.2.1 Engine speed (rpm), (Manufacturer's recommended production settings):

- Maximum speed at no load : 2350 to 2450
 - Low idle speed : 600 to 700
 - Speed at maximum torque : 1100 to 1300
Rated speed, (rpm):
 - For PTO use : 2200
 - For drawbar use : 2200

3.1.3 Cylinder & Cylinder Head:

Number : Four
 Disposition : Vertical, in-line
 Bore/stroke, (mm) : 100 / 118
 Capacity as specified by the applicant, (cc) : 3707
 Compression ratio : 18.2 (± 0.2) :1

T- 1509/2036/2021	INTERNATIONAL TRACTORS LIMITED, SONALIKA INTERNATIONAL WORLDTRAC 60 RX TRACTOR- COMMERCIAL- VARIANT (1st BATCH TEST)
	THIS TEST REPORT IS VALID UPTO: 31/01/2026

7.1 On the basis of test conducted the performance results have been summarized as evaluative (mandatory) / Non-evaluative (Non-mandatory) parameters applicable for qualifying Minimum Performance criteria as per Clause-4 (Table-1) of IS: 12207-2019 for acceptance of the tractor for the purpose of subsidies/NABARD financing are summarized as under:

Sl. No.	Characteristic	Category (Evaluative / Non-Evaluative)	Requirements as per IS: 12207-2019	Values declared by the applicant / (D) Requirement (R)	As observed	Whether meets the requirements (Yes/No)
1	2	3	4	5	6	7
7.1.1	PTO Performance:					
a)	Maximum power under 2 h test, (kW) (Natural ambient condition)	Evaluative	Declared value to be achieved with a tolerance of: $\pm 5\%$ for PTO power or engine power >26 kW, $\pm 10\%$ for PTO power or Engine power ≤ 26 kW.	36.3 (D)	35.7	Yes
b)	Power at rated engine speed, (kW)	Non Evaluative	-do-	36.3 (D)	35.5	Yes
c)	Specific fuel consumption corresponding to maximum power, (g/kWh)	Evaluative	+ 10% Max	265 (D)	275	Yes
d)	Maximum equivalent crankshaft torque, (Nm)	Non Evaluative	$\pm 8\%$	210 (D)	198.6	Yes
e)	Back-up torque, percent	Evaluative	12 percent, min.	12 (D) / (R) minimum	28.8	Yes
7.1.2	Drawbar performance:					
a)	Maximum drawbar pull with standard ballast corresponding to 15 percent wheel slip, (kN)	Evaluative	Minimum 70% of static mass of tractor with out/ standard ballast	17.64 Minimum (R) 17.47 (D)	20.86	Yes
b)	Maximum drawbar power with standard ballast as the case may be, kW	Evaluative	Minimum 80 % of PTO power as referred in SI No. i) a) of PTO performance in case of tractors having total static mass > 1500 kg Minimum 75 % of PTO power as referred in SI No. i) a) of PTO performance in case of light weight tractors having 1500 kg total static mass of tractor Minimum 75 % of the engine power as referred in SI No. i) a) of engine performance in case of tractors which do not have a PTO shaft.	28.6 Minimum (R) 29.04 (D)	29.8	Yes

1	2	3	4	5	6	7
---	---	---	---	---	---	---

T- 1509/2036/2021	INTERNATIONAL TRACTORS LIMITED, SONALIKA INTERNATIONAL WORLDTRAC 60 RX TRACTOR- COMMERCIAL- VARIANT (1st BATCH TEST)
	THIS TEST REPORT IS VALID UPTO: 31/01/2026

c)	Maximum transmission oil temperature (°C)	Evaluative	The declared value should not exceed the maximum value specified by oil company	130 (D)	108	Yes
7.1.3 Safety features:						
a)	Guards against moving and hot parts	Evaluative	Belt drives, pulleys, silencer, hydraulic pipes (As per IS 12239 (Part2))	Meets the requirement		Yes
b)	Lighting arrangement	Evaluative	As per CMVR	Meets the requirement		Yes
c)	Seating requirements (Tractors having more than 1150 mm rear track width)	Non-Evaluative	Should meet the requirements of IS: 12343 (As amended from time to time)	Does not meet the requirements		No
d)	Technical requirements for PTO shaft	Evaluative	Should meet the requirements of IS: 4931 (As amended from time to time)	Meets the requirement		Yes
e)	Dimensions of three-point linkage	Non-Evaluative	Should meet the requirements of IS: 4468 (Part-I) (As amended from time to time)	Does not meet the requirements		No
f)	Specifications of linkage drawbar	Evaluative	Should meet the requirements of IS 12953 and IS 12362 (Part 3) (As amended from time to time)	Meets the requirement		Yes
h)	1) Maximum travelling speed at rated engine speed in reverse gears, kmph	Evaluative	Should not exceed 20 kmph	25.30 kmph		Audible warning is provided
	2) Audible warning signal on tractor.	Evaluative	As soon as the travelling speed in reverse gear reaches to 20 kmph, an audible warning signal on tractor shall be activated.	Audible warning signal is activated, when travelling speed in reverse gear reaches to 20 kmph		Yes
7.1.4 Labelling of tractors (Provision of labelling plate):						
1	1) Make	Evaluative	Should conform to the requirements of CMVR along-with declared value of PTO in kW and year of manufacture in numerical MM YY Digit 01-12 in box No.1 for MM will represent the month and next two digit in the box No.2 for YY will represent the year of manufacturing	International Tractors Limited		Yes
	2) Model	Evaluative		SONALIKA INTERNATIONAL AL WORLDTRAC-60 RX		Yes
	3) Month & Year of manufacture	Evaluative		05/20		Yes
	3) Engine number	Evaluative		4100FL04C919 936F9		Yes
	4) Chassis number	Evaluative		FXDDH927703 MS		Yes
	5) Declaration-on of PTO power, (kW)	Evaluative		36.3		Yes
1	2	3	4	5	6	7

T- 1509/2036/2021	INTERNATIONAL TRACTORS LIMITED, SONALIKA INTERNATIONAL WORLDTRAC 60 RX TRACTOR- COMMERCIAL- VARIANT (1st BATCH TEST)
	THIS TEST REPORT IS VALID UPTO: 31/01/2026

7.1.5	Literature (Submission to test agency)					
(a)	Operator manual	Evaluative	Provided / Not Provided	Provided	Provided	Yes
(b)	Parts Catalogue	Evaluative	Provided / Not Provided	Provided	Provided	Yes
(c)	Workshop/ Service manual	Evaluative	Provided / Not Provided	Provided	Provided	Yes
7.1.6	Fitment of Roll Over Protective Structure (ROPS): for tractors having more than 1150 mm rear track width	Evaluative	ROPS should meet the requirement of IS:11821 or OECD code or equivalent International Standard	Provided	Not Fitted	Not Applicable
7.1.7	Standard accessories	Evaluative	Trailer hitch, front tow hook, linkage drawbar should be provided with tractor	Provided	Provided	Yes
7.1.8	Accessories (Optional)	Non Evaluative	Ballast weights if fitted should meet the requirement of CMVR.	Provided	Provided	Yes

7.2	CATEGORY OF BREAKDOWNS / DEFECTS:				
S. No.	Category of Breakdown	Category (Evaluative / Non-Evaluative)	Requirements as per IS: 12207-2019	As observed	Whether meets the requirement (Yes/No.)
1.	Critical breakdown	Evaluative	There is no 'critical breakdown' during the course of testing	None	Yes
2.	Major breakdowns	Evaluative	There are not more than 1 major breakdowns and neither of them is of repetitive nature	None	Yes
3.	Minor breakdowns	Evaluative	There are not more than 3 minor defects during the test and the frequency of each is not be more than two	None	Yes
4.	Total breakdowns	Evaluative	In no case, the total number of breakdowns should exceed four that is, (1 major + 3 minor) or 4 minor breakdowns	None	Yes

7.3 Salient Observations:

7.3.1 Laboratory tests:

7.3.1.1 PTO Performance:

- i) The maximum PTO power was recorded as **35.7 kW** against the declaration of **36.3 kW**, which meets the requirement of IS: 12207-2019 with regard to tolerance limit.
- ii) The specific fuel consumption corresponding to maximum power was recorded as **275 g/kWh** against the declaration of **265 g/kWh**, which is within the tolerance limit of IS: 12207-2019.
- iii) The maximum equivalent crankshaft torque was recorded as **198.6 N-m** against the declaration of **210 N-m**, which is within the permissible limit as specified in IS: 12207-2019.

T- 1509/2036/2021	INTERNATIONAL TRACTORS LIMITED, SONALIKA INTERNATIONAL WORLDTRAC 60 RX TRACTOR- COMMERCIAL- VARIANT (1st BATCH TEST)
	THIS TEST REPORT IS VALID UPTO: 31/01/2026

- iv) The backup torque is **28.8 %**
- v) Governor hunting was observed during the test. This should be looked into for necessary corrective action.

7.3.1.2 Drawbar performance test:

- i) Maximum drawbar pull in case of present sample with standard ballast corresponding to 15 percent wheel slip, (kN) was recorded as **20.86 kN** against the minimum requirement of **17.47 kN** which meets the requirement of IS: 12207-2019 with regard to tolerance limit.
- ii) Maximum drawbar power in case of present sample with standard ballasted condition was recorded as **29.8 kW** respectively against the minimum requirement of **28.6 kW** which meets the minimum requirement of IS: 12207-2019.

7.3.1.3 Three-point linkage:

- i) The parameter Lateral distance from lower hitch point to centre line of tractor does not meet the requirement of IS: 4468 (Part-1) -1979 (Reaffirmed 2014). This should be looked into for necessary corrective action.
- ii) Some of the parameters of three-point linkage conform to Cat. I and some of them conform to Cat.II. Keeping in view the spirit of standardization, necessary improvement may be incorporated.

7.3.1.4 Operator's seat:

Vertical distance from centre of differential lock pedal to seat index point is less than the minimum requirement of IS: 12343-1998: (Reaffirmed in 2014). This should be looked into for necessary corrective action.

7.4 Maintenance / Service Problems:

No noticeable maintenance or service problem was observed during the test.

7.5 Recommendation with regard to safety on tractor:

The following requirements, inter alia, may be considered for incorporation on the tractor:

- i) Spark arrester should be provided in the exhaust system as per IS: 12239(Part-2)-1999 (Re-affirmed in 2014).
- ii) PTO master shield should be provided around the PTO shaft as per IS: 12239(Part-2)-1999 (Re-affirmed in 2014).
- iii) Working clearance between the Position & Draft control lever of hydraulic system should be as per requirement of relevant test code as per IS: 12239(Part-2)-1999 (Re-affirmed in 2014).
- iv) Fuel shut-off knob should remain in "Stop" position as per IS:8133-1983 (Re-affirmed in 2014)

7.6 Adequacy of Literature:

7.6.1 Following literature of following tractor models were supplied with the test sample for reference during the test.

- a) Service Manual Part-1 & Part-2 for Sonalika international DI-Worldtrac 60 RX tractor model.
- b) Spare part catalogue Part-1 & Part-2 for Sonalika international DI-Worldtrac 60 RX tractor model
- c) Operator Manual for Sonalika international DI-Worldtrac 60 RX tractor model.

7.6.2 The supplied literature was found adequate; except the following

- a) Steering oil time schedule given in operator's manual does not match with specifications submitted by applicant.
- b) Routine service schedule and maintenance chart is not provided in service manual.

7.6.3 The literature should be brought out in national as well as other regional languages of India for guidance of users.

T- 1509/2036/2021	INTERNATIONAL TRACTORS LIMITED, SONALIKA INTERNATIONAL WORLDTRAC 60 RX TRACTOR- COMMERCIAL- VARIANT (1st BATCH TEST)
	THIS TEST REPORT IS VALID UPTO: 31/01/2026

8. CITIZEN CHARTER

Duration of Test	Test duration under citizen charter	Whether the report released within time frame given in the citizen charter	Remark
06 Months (July, 2020 to November, 2020)	10 Months	Yes	None

TESTING AUTHORITY:



C.S. RAGHUWANSHI
AGRICULTURAL ENGINEER



C.V. CHIMOTE
TEST ENGINEER



J.J.R. NARWARE
DIRECTOR

The report compiled by: **Pratyush Satya**, Senior Technical Assistant

9. APPLICANT'S COMMENTS

--None--

ANNEXURE - I

T- 1509/2036/2021	INTERNATIONAL TRACTORS LIMITED, SONALIKA INTERNATIONAL WORLDTRAC 60 RX TRACTOR- COMMERCIAL- VARIANT (1st BATCH TEST)
	THIS TEST REPORT IS VALID UPTO: 31/01/2026

TRACTOR RUN HOURS DURING TEST

A.	LABORATORY AND TRACK TESTS	HOURS
1.	Running-in	35.0
2.	Nominal speed test	1.9
3.	PTO performance test	4.4
4.	Drawbar performance test	4.4
C.	Miscellaneous test and other run hours including idle run, transportation, trials and preparation for test	5.0
	TOTAL:	50.7

T- 1509/2036/2021	INTERNATIONAL TRACTORS LIMITED, SONALIKA INTERNATIONAL WORLDTRAC 60 RX TRACTOR- COMMERCIAL- VARIANT (1 st BATCH TEST)
	THIS TEST REPORT IS VALID UPTO: 31/01/2026

ANNEXURE-II

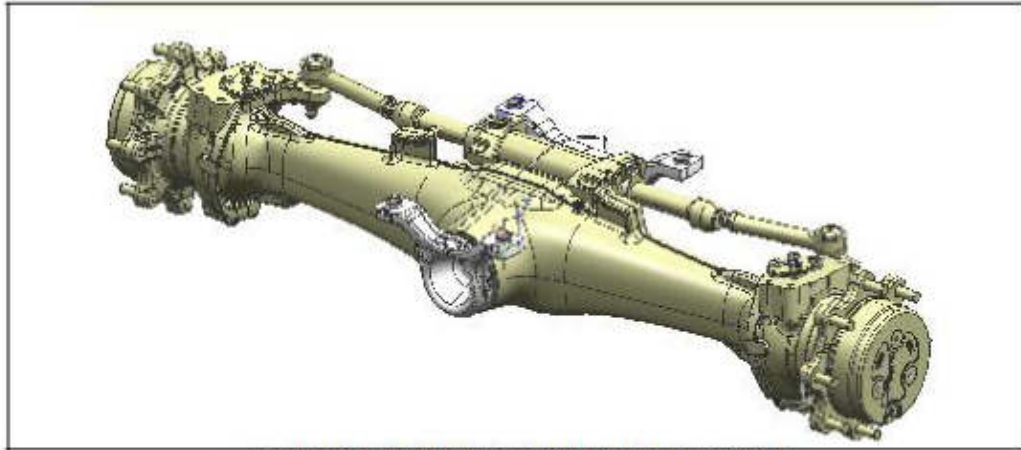

Base Model FRONT AXLE - WORLDTRAC 60 RX 4WD

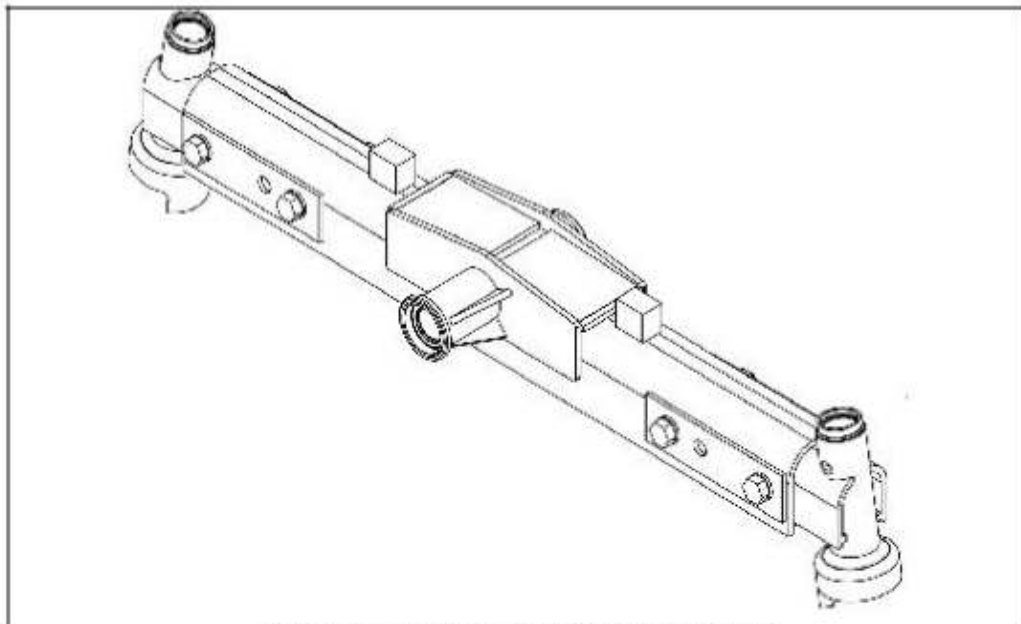

Variant Model FRONT AXLE - WORLDTRAC 60 RX